

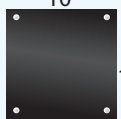







WALL MOUNT STRAIGHT ARM BRACKETS

For Hanging Signs or Banners

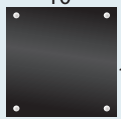
Please See Page 2 for Wall Mount Straight Arm Specifications

WITH FIXED, WELDED HANG TABS		36"	48"	60"
Wall Mount Baseplate Size 10" x 10" 		SB36-119	SB48-120	SB60-121
		SB36-122	SB48-123	SB60-124
		SB36-125	SB48-126	SB60-127
		SB36-128	SB48-129	SB60-130
WITH ADJUSTABLE (STAINLESS STEEL EYE BOLTS) HANG TABS		36"	48"	60"
Wall Mount Baseplate Size 10" x 10" 		N/A	*SB48-131-ADJ	*SB60-132-ADJ
		N/A	*SB48-133-ADJ	*SB60-134-ADJ
		N/A	*SB48-135-ADJ	*SB60-136-ADJ
		N/A	*SB48-137-ADJ	*SB60-138-ADJ

* All brackets with **adjustable hang tabs** allow the flexibility to compensate for a projecting soffit/jet work and are sold with two stainless steel eye bolts, washers, nuts and UV stabilized rubber washers to seal elements from entering the arm. Simply drill two holes at the desired eyebolt locations and the sign is ready to hang.

All steel brackets have a satin black finish and are sold as each.
For banner brackets two are required. Call today for more information!



Sign, Graphics, Awning & Marine Canvas Supplies
 125 Amara Street, East Providence, RI 02915
www.npcosignsupply.com

800-327-7562
401-438-4550 ~ FAX 401-438-1533
Daily Deliveries Throughout
New England and Nearby New York

Rounded Top Displayed Below. Please see Page 1 for all post styles.

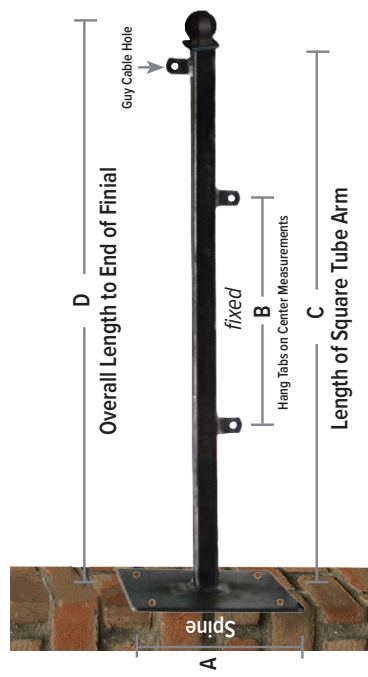

WALL MOUNT Straight Arm Brackets Specification Chart

• FOUR UNIQUE STYLE FINIALS

• EXTRA WIDE SPINE (BASE PLATE)

• FOR MORE SURFACE ATTACHMENT TO WALL



Call or visit our website for additional information! Offers valid as of 02/28/2025. Offers are subject to change without notice.

Special Notes:
 • All steel brackets have a satin black finish.
 • Custom Steel Bracket work available - scaled drawing required for estimating.

Item #	End Style	A	B	C	D	Spine	Arm	Hang Tabs	Guy Cable Tab
SB36-119	FLAT	10"	20"	36"	36 1/2"	1/4" X 10" X 10" X 10", w/ 9/16" Holes	1 1/2" X 1 1/2" X 1 1/8" Wall	1/4" X 1" w/ 7/16" Holes	1/4" X 1" w/ 7/16" Hole
SB48-120	FLAT	10"	28"	48"	48 1/2"	1/4" X 10" X 10" X 10", w/ 9/16" Holes	1 1/2" X 1 1/2" X 1 1/8" Wall	1/4" X 1" w/ 7/16" Holes	1/4" X 1" w/ 7/16" Hole
SB60-121	FLAT	10"	40"	60"	60 1/2"	1/4" X 10" X 10" X 10", w/ 9/16" Holes	1 1/2" X 1 1/2" X 1 1/8" Wall	1/4" X 1" w/ 7/16" Holes	1/4" X 1" w/ 7/16" Hole
SB36-122	BALL	10"	20"	36"	38 1/2"	1/4" X 10" X 10" X 10", w/ 9/16" Holes	1 1/2" X 1 1/2" X 1 1/8" Wall	1/4" X 1" w/ 7/16" Holes	1/4" X 1" w/ 7/16" Hole
SB48-123	BALL	10"	28"	48"	50 1/2"	1/4" X 10" X 10" X 10", w/ 9/16" Holes	1 1/2" X 1 1/2" X 1 1/8" Wall	1/4" X 1" w/ 7/16" Holes	1/4" X 1" w/ 7/16" Hole
SB60-124	BALL	10"	40"	60"	62 1/2"	1/4" X 10" X 10" X 10", w/ 9/16" Holes	1 1/2" X 1 1/2" X 1 1/8" Wall	1/4" X 1" w/ 7/16" Holes	1/4" X 1" w/ 7/16" Hole
SB36-125	FLAT SPEAR	10"	20"	36"	44 1/2"	1/4" X 10" X 10" X 10", w/ 9/16" Holes	1 1/2" X 1 1/2" X 1 1/8" Wall	1/4" X 1" w/ 7/16" Holes	1/4" X 1" w/ 7/16" Hole
SB48-126	FLAT SPEAR	10"	28"	48"	56 1/2"	1/4" X 10" X 10" X 10", w/ 9/16" Holes	1 1/2" X 1 1/2" X 1 1/8" Wall	1/4" X 1" w/ 7/16" Holes	1/4" X 1" w/ 7/16" Hole
SB60-127	FLAT SPEAR	10"	40"	60"	68 1/2"	1/4" X 10" X 10" X 10", w/ 9/16" Holes	1 1/2" X 1 1/2" X 1 1/8" Wall	1/4" X 1" w/ 7/16" Holes	1/4" X 1" w/ 7/16" Hole
SB36-128	SQ. SPEAR	10"	20"	36"	42 1/4"	1/4" X 10" X 10" X 10", w/ 9/16" Holes	1 1/2" X 1 1/2" X 1 1/8" Wall	1/4" X 1" w/ 7/16" Holes	1/4" X 1" w/ 7/16" Hole
SB48-129	SQ. SPEAR	10"	28"	48"	54 1/4"	1/4" X 10" X 10" X 10", w/ 9/16" Holes	1 1/2" X 1 1/2" X 1 1/8" Wall	1/4" X 1" w/ 7/16" Holes	1/4" X 1" w/ 7/16" Hole
SB60-130	SQ. SPEAR	10"	40"	60"	66 1/4"	1/4" X 10" X 10" X 10", w/ 9/16" Holes	1 1/2" X 1 1/2" X 1 1/8" Wall	1/4" X 1" w/ 7/16" Holes	1/4" X 1" w/ 7/16" Hole
*SB48-131-ADJ	FLAT	10"	adjustable	48"	48 1/2"	1/4" X 10" X 10" X 10", w/ 9/16" Holes	1 1/2" X 1 1/2" X 1 1/8" Wall	5/16" S.S. Eyebolts w/HDWE	1/4" X 1" w/ 7/16" Hole
*SB60-132-ADJ	FLAT	10"	adjustable	60"	60 1/2"	1/4" X 10" X 10" X 10", w/ 9/16" Holes	1 1/2" X 1 1/2" X 1 1/8" Wall	5/16" S.S. Eyebolts w/HDWE	1/4" X 1" w/ 7/16" Hole
*SB48-133-ADJ	BALL	10"	adjustable	48"	50 1/2"	1/4" X 10" X 10" X 10", w/ 9/16" Holes	1 1/2" X 1 1/2" X 1 1/8" Wall	5/16" S.S. Eyebolts w/HDWE	1/4" X 1" w/ 7/16" Hole
*SB60-134-ADJ	BALL	10"	adjustable	60"	62 1/2"	1/4" X 10" X 10" X 10", w/ 9/16" Holes	1 1/2" X 1 1/2" X 1 1/8" Wall	5/16" S.S. Eyebolts w/HDWE	1/4" X 1" w/ 7/16" Hole
*SB48-135-ADJ	FLAT SPEAR	10"	adjustable	48"	56 1/2"	1/4" X 10" X 10" X 10", w/ 9/16" Holes	1 1/2" X 1 1/2" X 1 1/8" Wall	5/16" S.S. Eyebolts w/HDWE	1/4" X 1" w/ 7/16" Hole
*SB60-136-ADJ	FLAT SPEAR	10"	adjustable	60"	68 1/2"	1/4" X 10" X 10" X 10", w/ 9/16" Holes	1 1/2" X 1 1/2" X 1 1/8" Wall	5/16" S.S. Eyebolts w/HDWE	1/4" X 1" w/ 7/16" Hole
*SB48-137-ADJ	SQ. SPEAR	10"	adjustable	48"	54 1/2"	1/4" X 10" X 10" X 10", w/ 9/16" Holes	1 1/2" X 1 1/2" X 1 1/8" Wall	5/16" S.S. Eyebolts w/HDWE	1/4" X 1" w/ 7/16" Hole
*SB60-138-ADJ	SQ. SPEAR	10"	adjustable	60"	66 1/4"	1/4" X 10" X 10" X 10", w/ 9/16" Holes	1 1/2" X 1 1/2" X 1 1/8" Wall	5/16" S.S. Eyebolts w/HDWE	1/4" X 1" w/ 7/16" Hole

* All brackets with adjustable hang tabs allow the flexibility to compensate for a projecting soffit/jet work and are sold with two stainless steel eye bolts, washers, nuts and UV stabilized rubber washers to seal elements from entering the arm. Simply drill two holes at the desired hang tab locations and the sign is ready to hang.

Rounded Top Displayed Below.

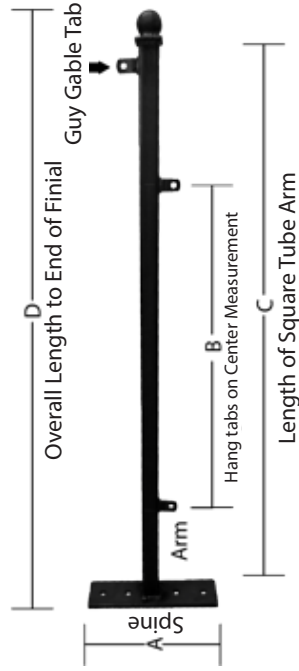

POLE MOUNT Straight Arm Brackets Specification Chart

NARROW BASEPLATE SPECIFICALLY DESIGNED FOR POLE MOUNT APPLICATIONS.

Special Notes:

- All steel brackets have a satin black finish.
- Custom Steel Bracket work available - scaled drawing required for estimating.
- * Pole mount straight arm brackets can be mounted to walls

Call or visit our website for additional information!
Offers valid as of 02/28/2025. Offers are subject to change without notice.

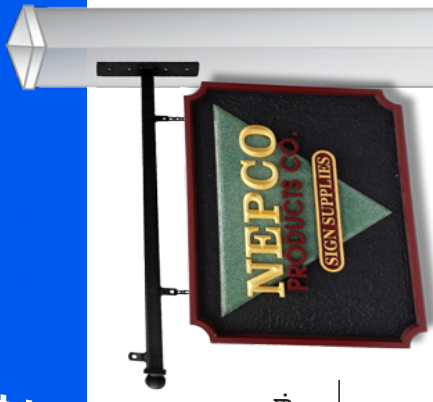

Pole Mount Baseplate Size

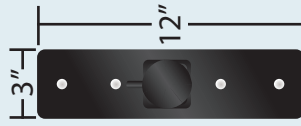

Fixed, Welded Hang Tabs Only

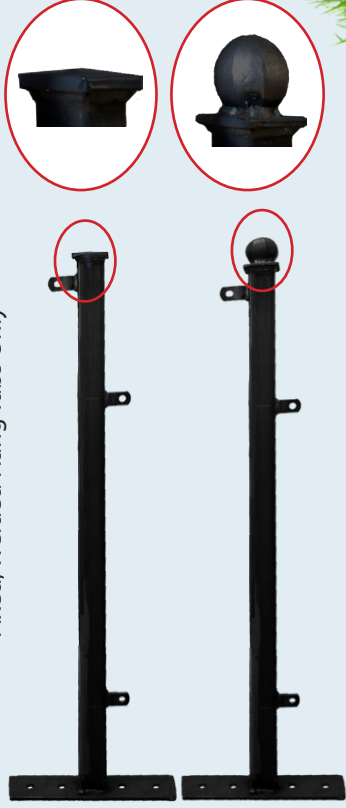

Item #	End Style	A	B	C	D	Spine	Arm	Hang Tabs	Guy Cable Tab
SB36-142	FLAT	12"	20"	36"	36 1/2"	3/8" X 12" X 3" w/ 9/16" Holes	1 1/2" X 1 1/2" X 1/8" Wall	1/4" X 1" w/ 7/16" Holes	1/4" X 1" w/ 7/16" Hole
SB48-143	FLAT	12"	28"	48"	48 1/2"	3/8" X 12" X 3" w/ 9/16" Holes	1 1/2" X 1 1/2" X 1/8" Wall	1/4" X 1" w/ 7/16" Holes	1/4" X 1" w/ 7/16" Hole
SB60-144	FLAT	12"	40"	60"	60 1/2"	3/8" X 12" X 3" w/ 9/16" Holes	1 1/2" X 1 1/2" X 1/8" Wall	1/4" X 1" w/ 7/16" Holes	1/4" X 1" w/ 7/16" Hole
SB36-145	BALL	12"	20"	36"	38 1/2"	3/8" X 12" X 3" w/ 9/16" Holes	1 1/2" X 1 1/2" X 1/8" Wall	1/4" X 1" w/ 7/16" Holes	1/4" X 1" w/ 7/16" Hole
SB48-146	BALL	12"	28"	48"	50 1/2"	3/8" X 12" X 3" w/ 9/16" Holes	1 1/2" X 1 1/2" X 1/8" Wall	1/4" X 1" w/ 7/16" Holes	1/4" X 1" w/ 7/16" Hole
SB60-147	BALL	12"	40"	60"	62 1/2"	3/8" X 12" X 3" w/ 9/16" Holes	1 1/2" X 1 1/2" X 1/8" Wall	1/4" X 1" w/ 7/16" Holes	1/4" X 1" w/ 7/16" Hole

NEW ENGLAND SERIES SCROLL BRACKETS

Please See Page 5 for all New England Style Specifications

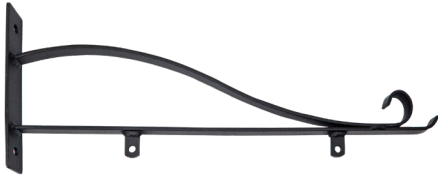

ESSEX

30" SB30-100
42" SB42-101

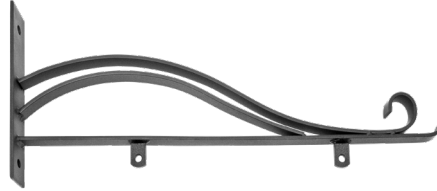

NANTUCKET

30" SB30-100
42" SB42-101



WICKFORD

30" SB30-104
42" SB42-105



MOUNT HOPE

30" SB30-108
42" SB42-109



NEWPORT

36" SB36-110
48" SB48-111

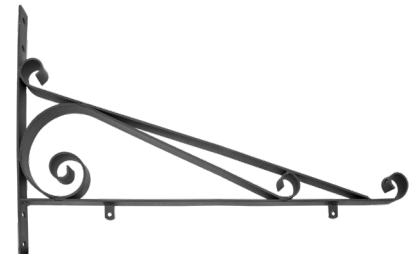

CHATHAM

42" SB42-113
54" SB54-114

**Newport is specifically designed for use with oval and circle type shapes!*



SLATER

30" SB30-115
42" SB42-116

All steel brackets have a satin black finish and are sold as each.
Call today for more information!



Sign, Graphics, Awning & Marine Canvas Supplies
125 Amarat Street, East Providence, RI 02915
www.nepcosignsupply.com

800-327-7562
401-438-4550 ~ FAX 401-438-1533

**Daily Deliveries Throughout
New England and Nearby New York**

Chatham style displayed below.
Please see Page 1 for all
New England image styles.

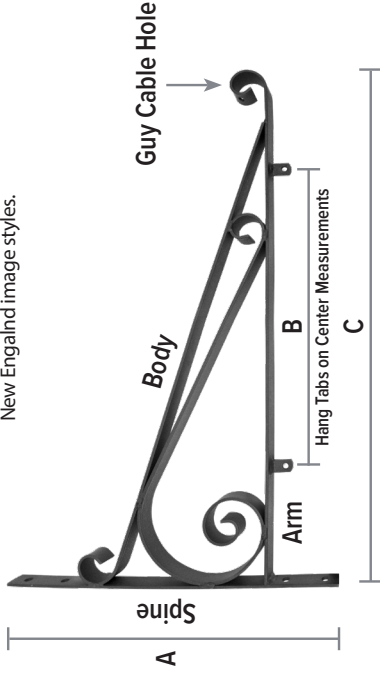

NEW ENGLAND SERIES SCROLL BRACKET SPECIFICATIONS

Special Notes:

- Chatham and Newport spine has four holes for additional support.
- All Brackets have a satin black finish.
- Custom Steel Bracket work available - scaled drawing required for estimating.

Call or visit our website for additional information!
Offers valid as of 02/28/2025. Offers are subject to change without notice.

Description	Item #	A	B	C	Spine	Body	Arm	Hang Tabs	Guy Cable Hole
30" Essex	SB30-100	11"	14"	30"	1/4" x 2" w/ 9/16" holes	1/4" x 1"	1/4" x 1"	1/4" x 1" w/ 7/16" holes	N/A
42" Essex	SB42-101	13 1/2"	24"	42"	1/4" x 2" w/ 9/16" holes	1/4" x 1 1/2"	1/4" x 1 1/2"	1/4" x 1" w/ 7/16" holes	1/2"
30" Nantucket	SB30-102	11 1/2"	14"	30"	1/4" x 2" w/ 9/16" holes	1/4" x 1"	1/4" x 1"	1/4" x 1" w/ 7/16" holes	N/A
42" Nantucket	SB42-103	14 1/2"	24"	42"	1/4" x 2" w/ 9/16" holes	1/4" x 1 1/2"	1/4" x 1 1/2"	1/4" x 1" w/ 7/16" holes	1/2"
30" Wickford	SB30-104	11 1/4"	14"	30"	1/4" x 2" w/ 9/16" holes	1/4" x 1"	1/4" x 1"	1/4" x 1" w/ 7/16" holes	N/A
42" Wickford	SB42-105	13 1/2"	24"	42"	1/4" x 2" w/ 9/16" holes	1/4" x 1 1/2"	1/4" x 1 1/2"	1/4" x 1" w/ 7/16" holes	1/2"
30" Mount Hope	SB30-108	10 1/2"	14"	30"	1/4" x 4" w/ 9/16" holes	1/4" x 1/2"	3/4" x 3/4"	1/4" x 1" w/ 7/16" holes	N/A
42" Mount Hope	SB42-109	11"	24"	42"	1/4" x 4" w/ 9/16" holes	1/4" x 1/2"	3/4" x 3/4"	1/4" x 1" w/ 7/16" holes	N/A
36" Newport	SB36-110	28"	16 1/2"	36"	1/4" x 1 1/2" w/ 9/16" holes	1/4" x 1 1/2"	1/4" x 1 1/2"	1/4" x 1" w/ 7/16" holes	1/2"
48" Newport	SB48-111	32 1/2"	22 1/4"	48"	1/4" x 1 1/2" w/ 9/16" holes	1/4" x 1 1/2"	1/4" x 1 1/2"	1/4" x 1" w/ 3/8" holes	1/2"
42" Chatham	SB42-113	26"	24"	42"	1/4" x 1 1/2" w/ 9/16" holes	1/4" x 1 1/2"	1/4" x 1 1/2"	1/4" x 1" w/ 3/8" holes	1/2"
54" Chatham	SB54-114	25 1/2"	34"	54"	1/4" x 1 1/2" w/ 9/16" holes	1/4" x 1 1/2"	1/4" x 1 1/2"	1/4" x 1" w/ 3/8" holes	1/2"
30" Slater	SB30-115	12"	14"	30"	1/4" x 2" w/ 9/16" holes	1/4" x 1"	1/4" x 1"	1/4" x 1" w/ 3/8" holes	N/A
42" Slater	SB42-116	13 1/2"	24"	42"	1/4" x 2" w/ 9/16" holes	1/4" x 1 1/2"	1/4" x 1 1/2"	1/4" x 1" w/ 3/8" holes	1/2"

PREMIUM SERIES & STANDARD SERIES SCROLL BRACKETS SPECIFICATIONS

Premium Series Scroll Bracket

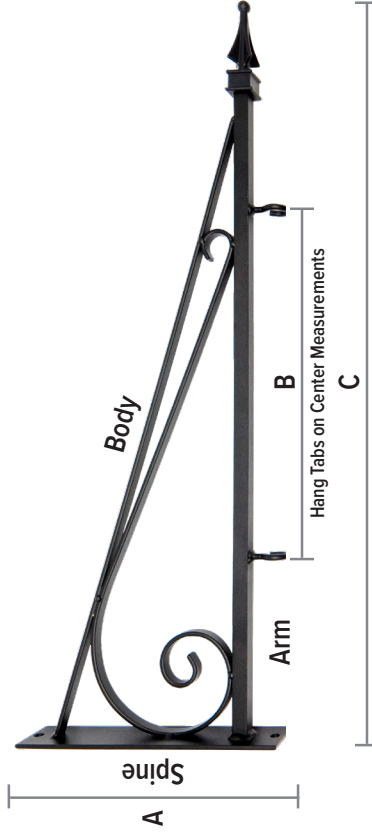

Standard Series Scroll Bracket

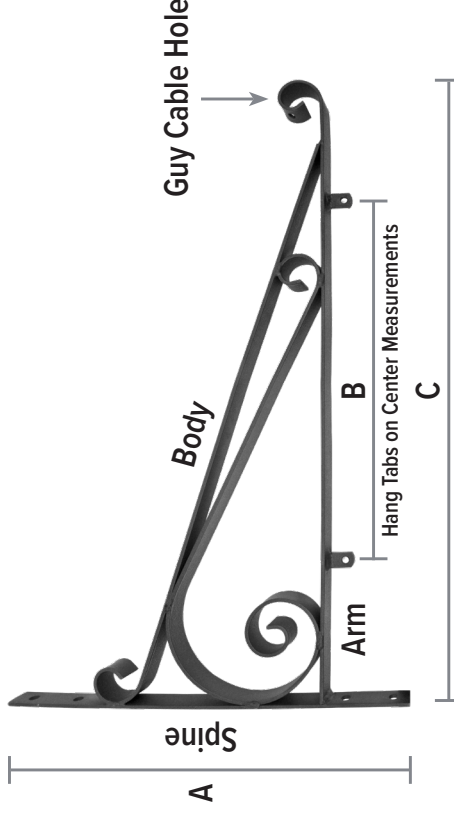

Description	Item #	A	B	C	Spine	Body	Arm	Hang Tabs
20" Premium Scroll Bracket	SB20-Prem	8"	8"	20"	3/16" x 1 1/2" w/ 3/8" Holes	3/16" x 1/2"	1/2" x 1/2"	3/16" Wire w/ 1/2" Hole
26" Premium Scroll Bracket	SB26-Prem	9"	12"	26"	3/16" x 2" w/ 3/8" Holes	3/16" x 1/2"	5/8" x 5/8"	1/4" Wire w/ 5/8" Hole
30" Premium Scroll Bracket	SB30-Prem	10 1/2"	14"	30"	3/16" x 2" w/ 3/8" Holes	3/16" x 1/2"	5/8" x 5/8"	1/4" Wire w/ 5/8" Hole
36" Premium Scroll Bracket	SB36-Prem	10 1/2"	20"	36"	3/16" x 2" w/ 3/8" Holes	3/16" x 1/2"	5/8" x 5/8"	1/4" Wire w/ 5/8" Hole
42" Premium Scroll Bracket	SB42-Prem	11 3/4"	21 7/8"	42"	3/16" x 2" w/ 3/8" Holes	3/16" x 1/2"	5/8" x 5/8"	1/4" Wire w/ 5/8" Hole
18" Standard Scroll Bracket	SB18	11"	6 1/4"	18"	1/16" x 1 1/4" w 1/4" Holes	1/16" x 3/4"	1/16" x 3/4"	3/8" Washers
24" Standard Scroll Bracket	SB24	11"	10 1/4"	24"	1/8" x 1 1/4" w/ 1/4" Holes	1/8" x 1"	1/8" x 1"	3/8" Washers
30" Standard Scroll Bracket	SB30	15"	17 1/4"	30"	1/8" x 1 1/2" w/ 1/4" Holes	1/8" x 1"	1/8" x 1"	3/8" Washers
36" Standard Scroll Bracket	SB36	15"	20 7/8"	36"	1/16" x 1 1/2" w/ 1/4" Holes	1/16" x 1"	1/16" x 1"	3/8" Washers
42" Standard Scroll Bracket	SB42	16"	24"	42"	1/8" x 1 1/2" w/ 1/4" Holes	1/8" x 1"	1/8" x 1"	3/8" Washers
48" Standard Scroll Bracket	SB48	16"	23"	48"	1/8" x 1 1/2" w/ 1/4" Holes	1/8" x 1"	1/8" x 1"	3/8" Washers

*Custom made for NEPCO, therefore pricing will be higher on 30" than 48".

Offers Valid as of 02/28/2025 Offers are subject to change without notice.

Projection Stationary Bracket!



Projection stationary brackets are welded & prepunched using the highest grade of 1/4" wall plate. Horizontal projection tubes are made of 1" x 1" x 1/8" heavy square steel with end caps for protection from moisture penetration. Each bracket is textured powder coated black for ultimate weather protection.

SB26-139 IS NOW BACK IN STOCK!

☺Thank you for your patience!☺

3 Size Options!

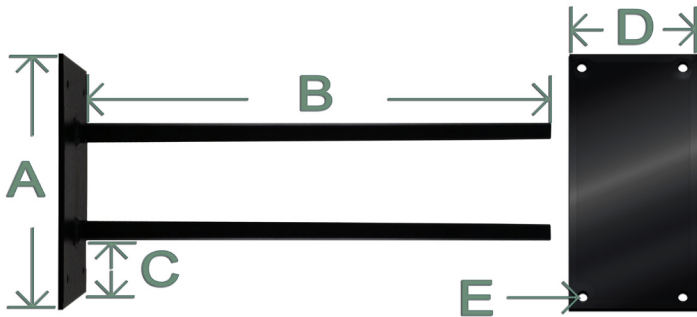

ITEM NUMBER	A	B	C	D	E
SB26-139	13"	26"	3"	1/4" X 8"	7/16"
SB34-140	18"	34"	4"	1/4" X 8"	7/16"
SB46-141	23"	46"	5"	1/4" X 8"	7/16"

MOUNTING EXAMPLES

All Projection Stationary Brackets can be used with Single Face & Double Faced Applications!

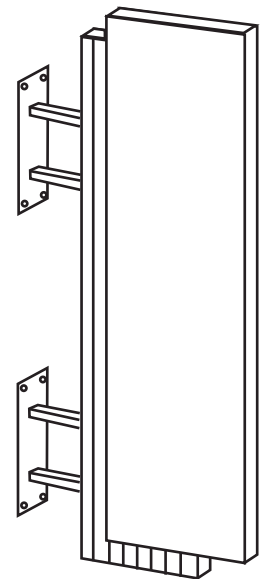
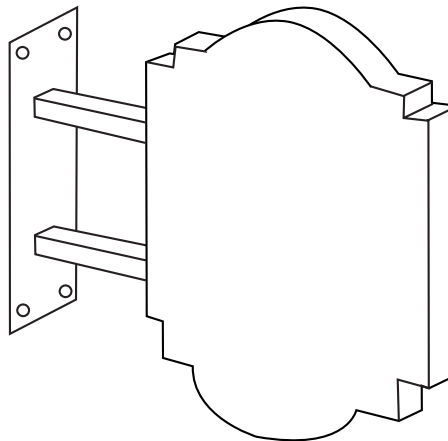
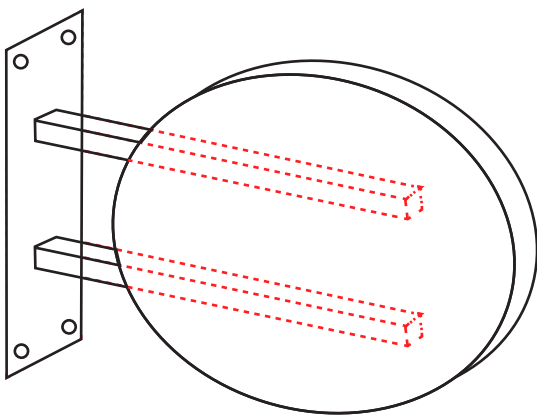

THE FIRST EVER UNIVERSAL SIGN BRACKETS

Designed to be used with a wide variety of signage types including, but not limited to, **high density urethane, wood, illuminated & non-illuminated** types of signage.

4 Bracket Options!

ITEM #	VERTICAL DIMENSION	HORIZONTAL DIMENSION
UNIV-XSM	7.5"	6-3/16"
UNIV-SM	13.5"	11.5"
UNIV-MED	24"	22"
UNIV-LG	24"	44"

Universal Sign Brackets are welded & prepunched using the highest grade of 3/16" steel available. Each bracket is powder coated white for ultimate protection and has four 2 1/4" holes in each corner & 1/4" counter sink for multifastening options.

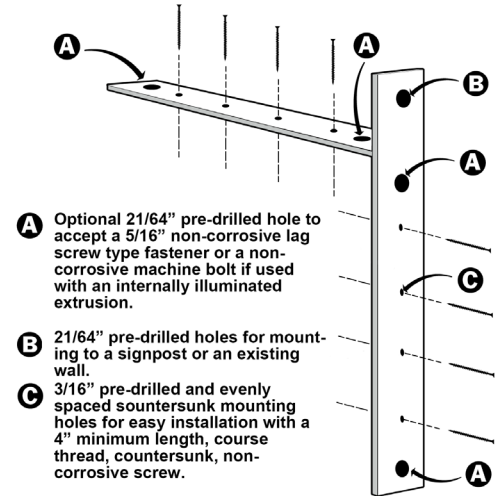

SIGN MOUNTING EXAMPLES

Between Pole Mount

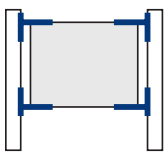

Bottom/Top Mount Existing

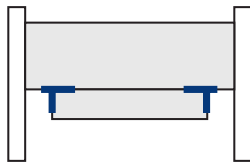

Multi Between Pole

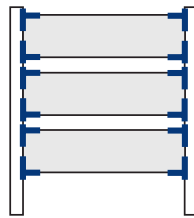

Wall Mount Projection

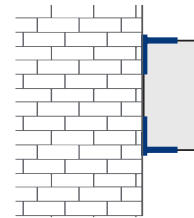

Between Pole Mix & Match

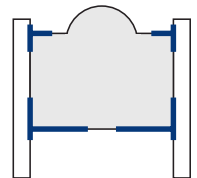

Under Canopy Mount

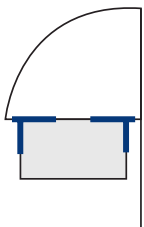

Double Projection

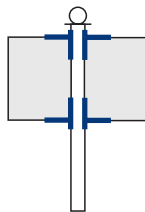

Side Between Pole

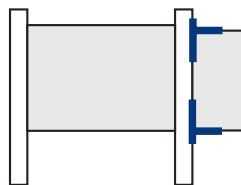

Single Bracket Projection

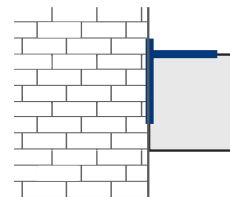

Single Pole Projection

